

1

**1) MONTAŽA DVOKRILNOG ORMARIĆA**

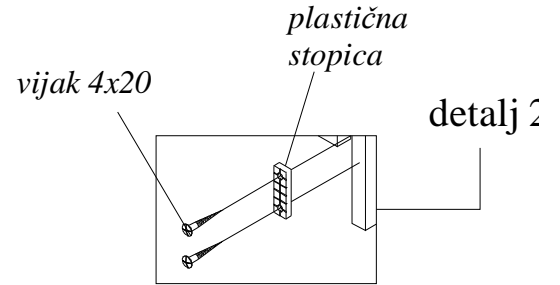
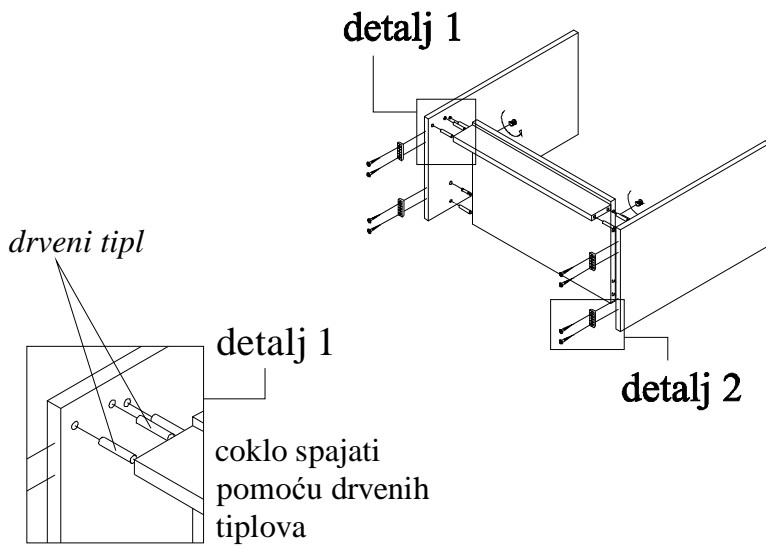

plastičnu stopicu pričvrstiti na dno bočnih stranica pomoću vijaka 4 x 20

2

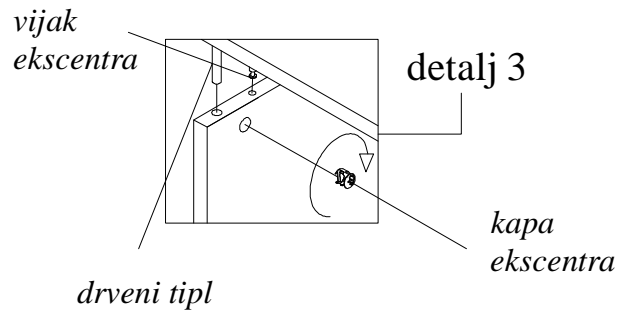
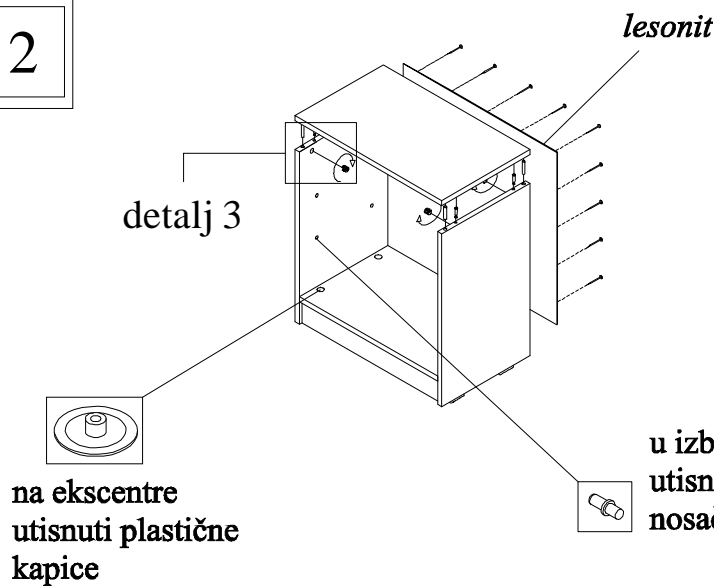

na ekscentre utisnuti plastične kapice

u izbušene rupe utisnuti metalni nosač police

za spajanje šarke na vrata koristiti vijak 4 x 16

3

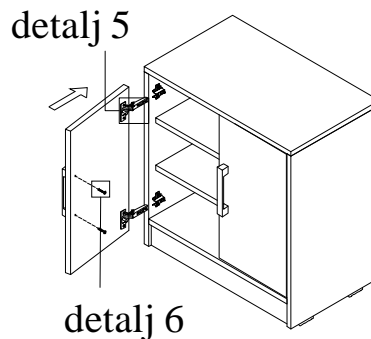
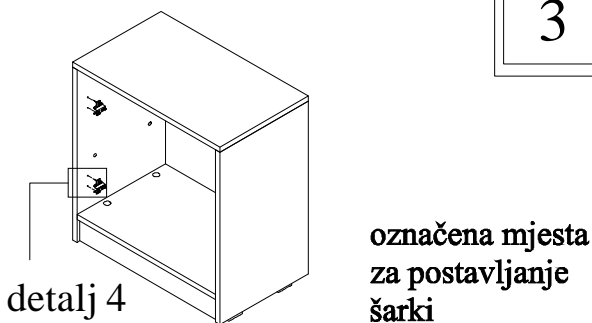

4

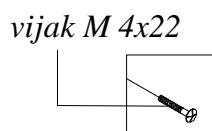
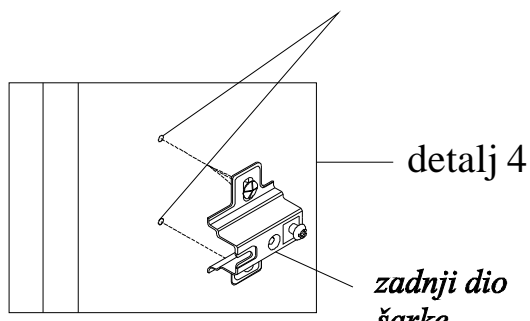

detali 6

izgled elementa nakon montaže

5

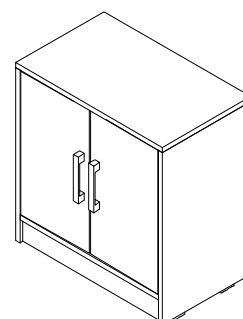

6

2) **MONTAŽA JEDNOKRILNOG ORMARIĆA SA LATICOM**

drveni tipl

detalj 7

coklo spajati  
pomoću drvenih  
tiplova

detalj 7

detalj 8

vijak 4x20

plastična  
stopica

detalj 8

plastičnu stopicu pričvrstiti  
na dno bočnih stranica  
pomoću vijaka 4 x 20

7

**MONTAŽA LATICE**

detalj 9

vijak 4 x 35

vijak za ručke  
4 x 45

8

lesonit

ekser za lesonit

konfirmat  
vijak

detalj 9

drveni tipl

točkić klizača je na zadnjem  
kraju

detalj 10

vijak 3,5 x 16

detalj 10

9

10

detalj 11

u izbušene rupe  
utisnuti metalni  
nosač policeprilikom montaže, vodilicu  
postaviti tako da se izravna  
sa prednjim dijelom kantane  
stranena ekscentre  
utisnuti plastične  
kapice

vodilica latice

vijak 3,5 x 16

detalj 11

11

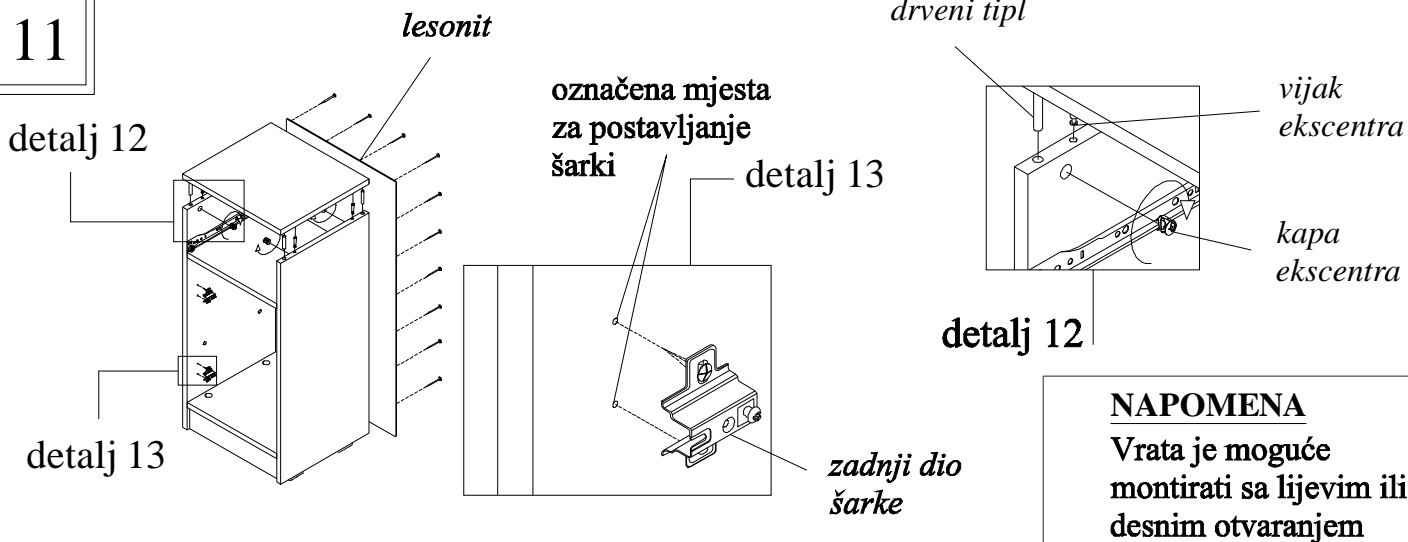

**NAPOMENA**  
Vrata je moguće montirati sa lijevim ili desnim otvaranjem

12

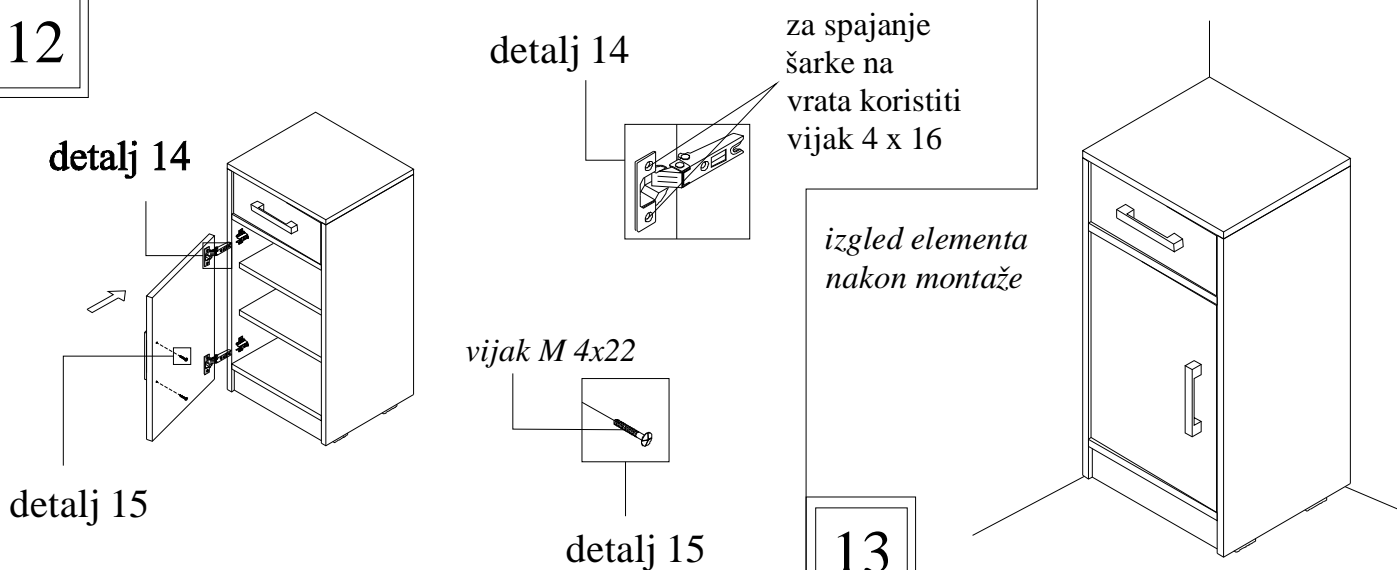

### 3) MONTAŽA JEDNOKRILNOG ORMARA

14

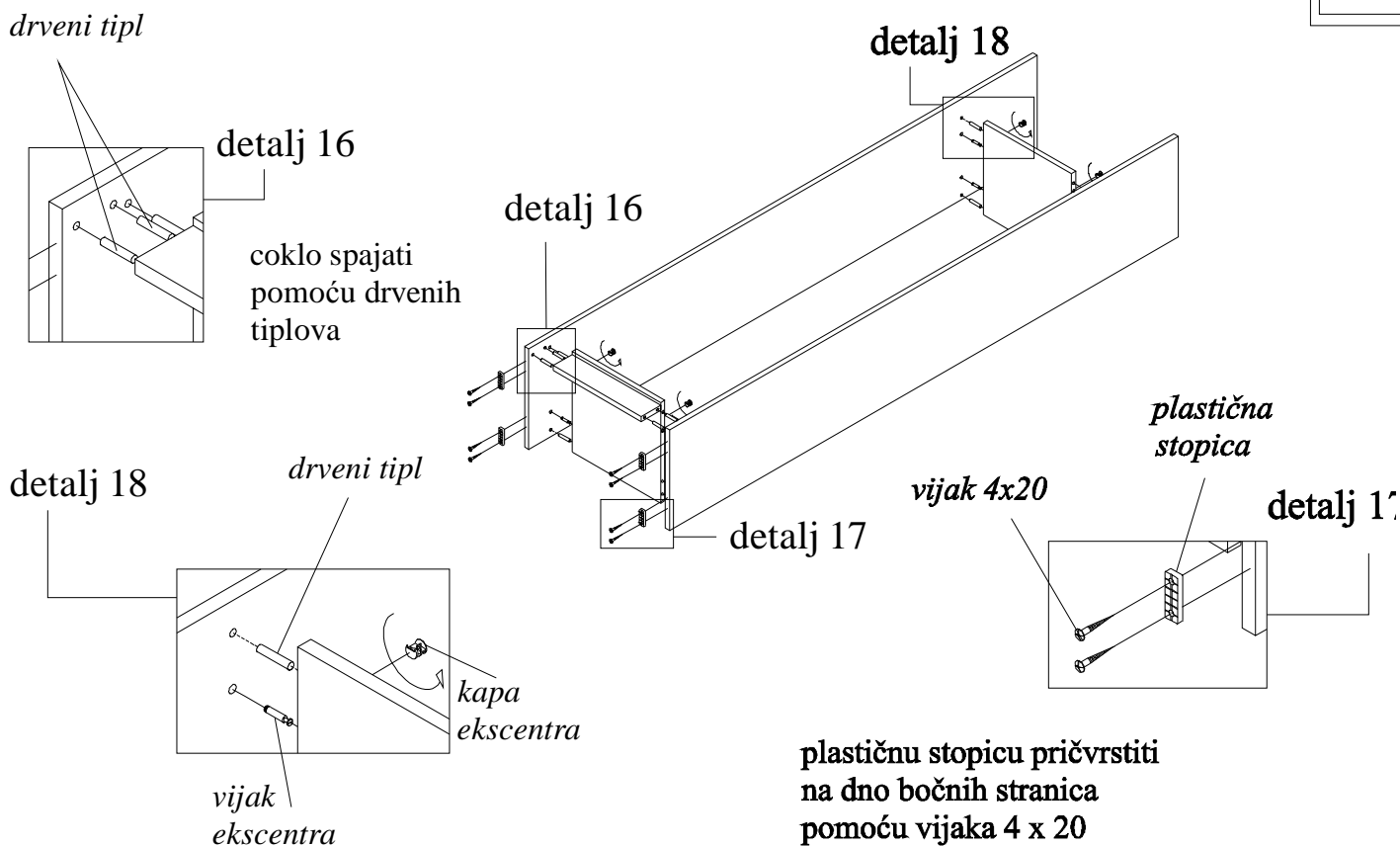

15

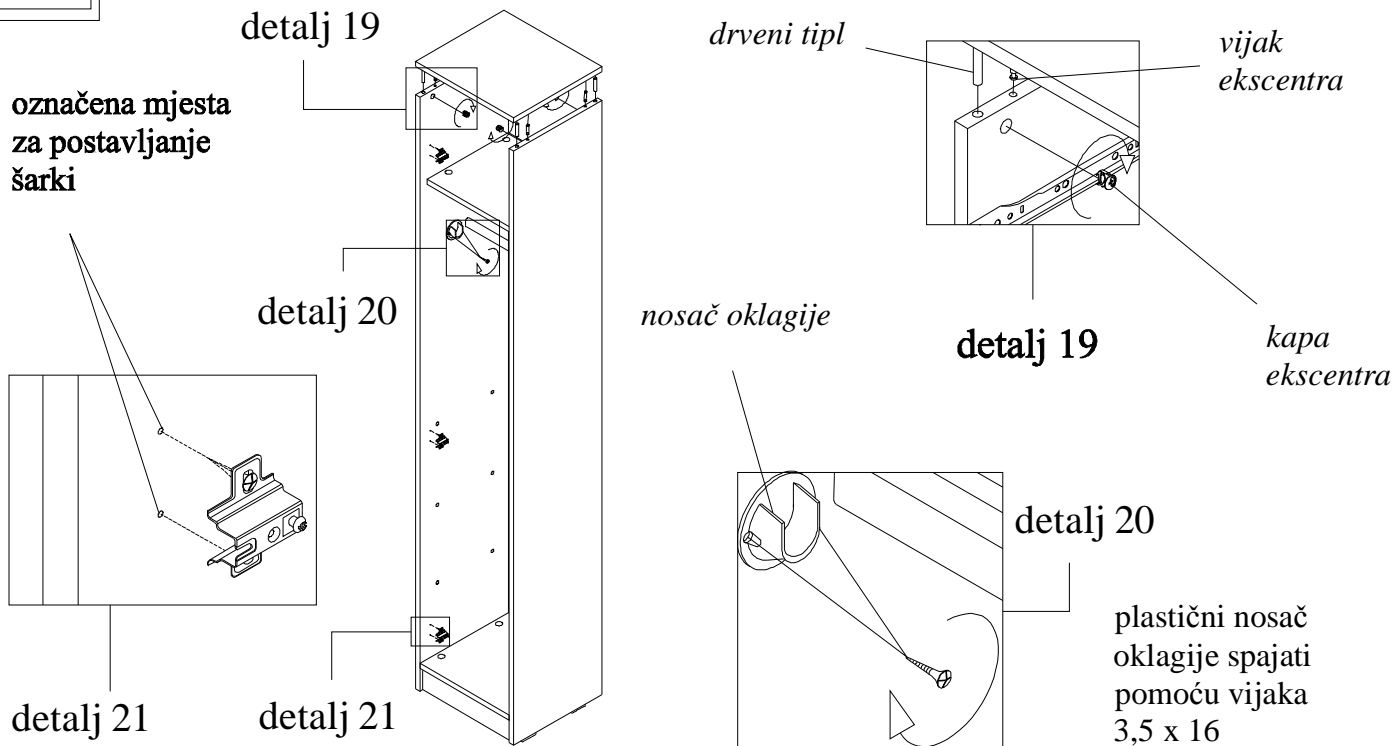

16

**NAPOMENA**

Vrata je moguće montirati sa lijevom ili desnim otvaranjem

17

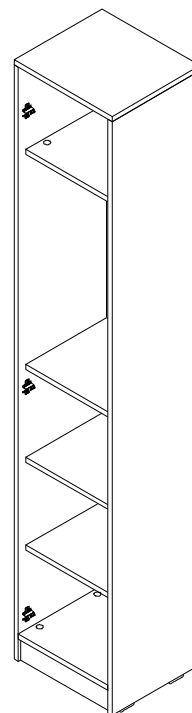
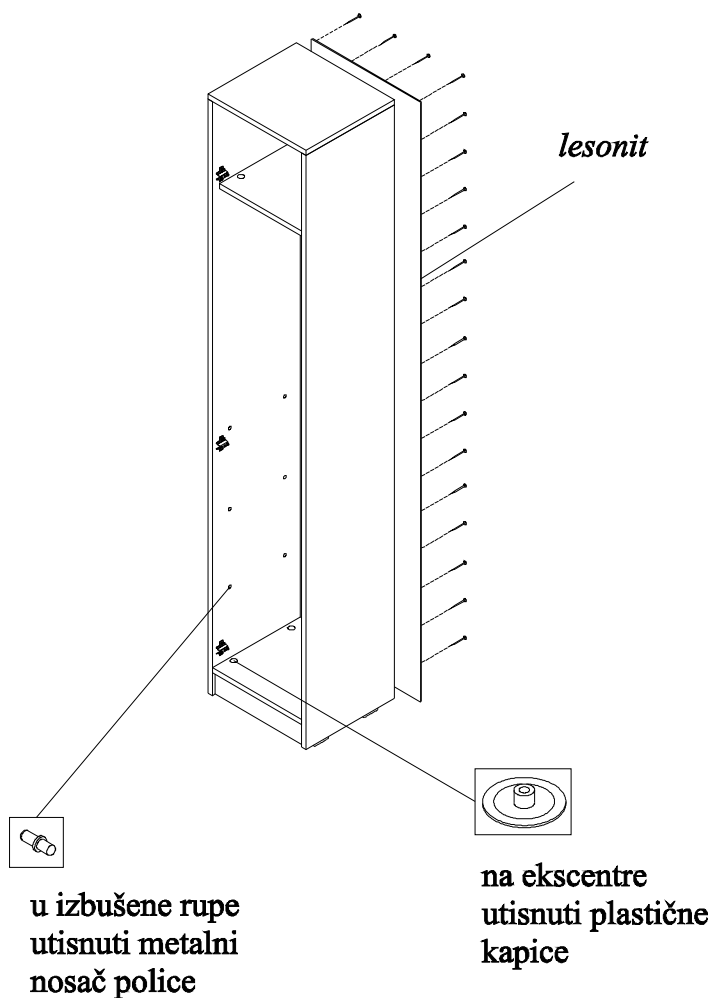

18

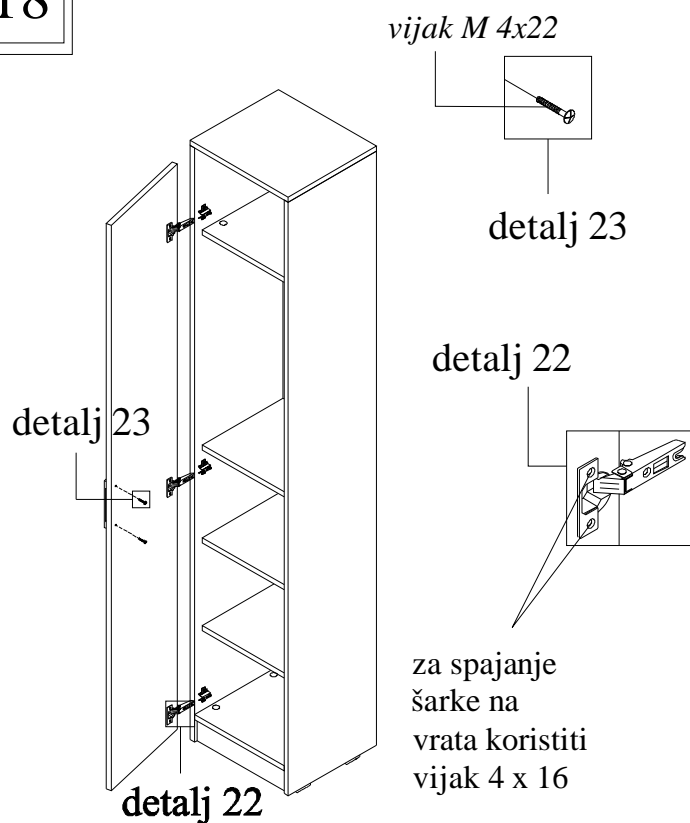

izgled elementa nakon montaže

19

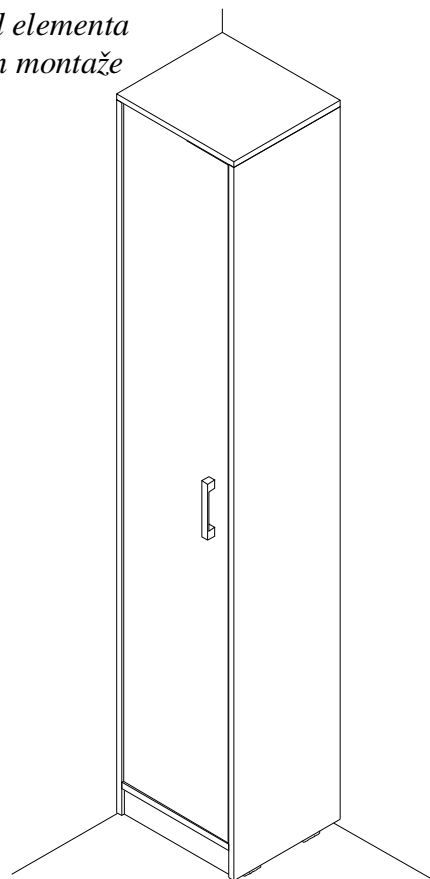

20

#### 4) MONTAŽA VJEŠALICE I OGLEDALA

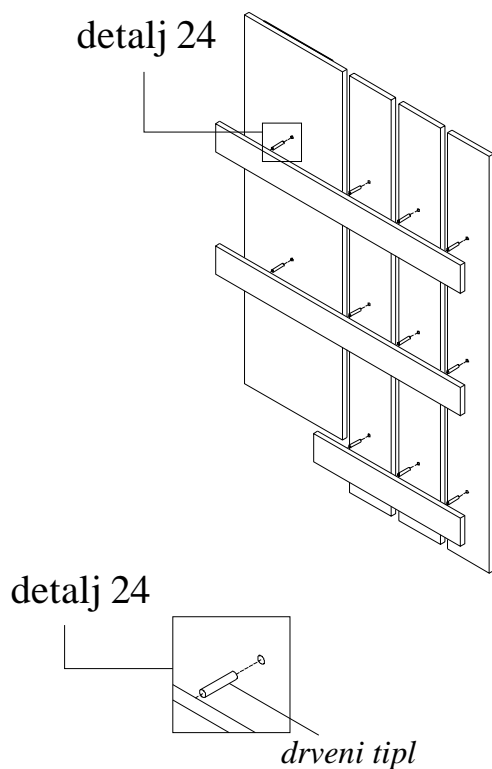

##### NAPOMENA

Prilikom montaže ogledala i vješalice obratiti pažnju da podloga na kojoj se montira bude čista i mekana kako ne bih došlo do oštećenja istih.

21

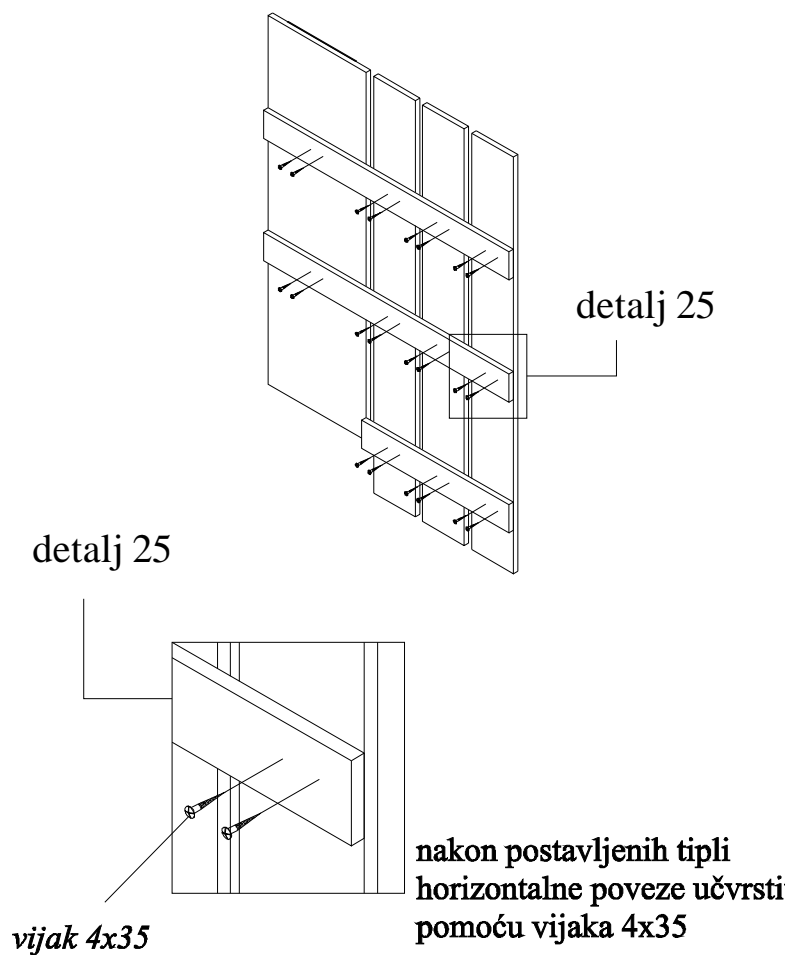

22

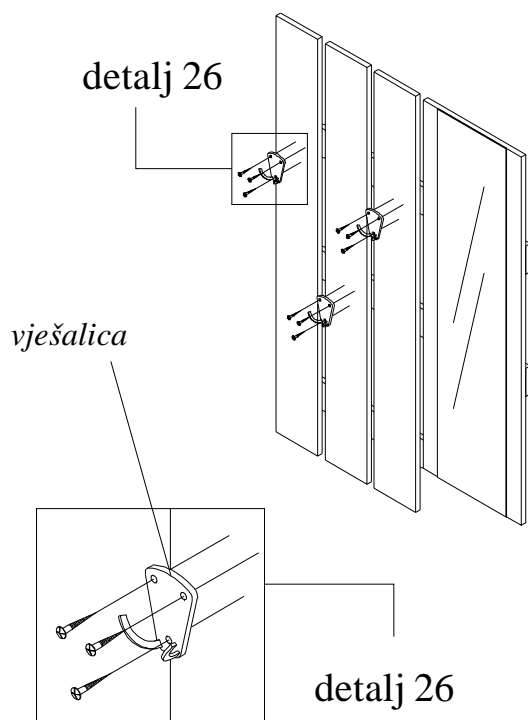

23

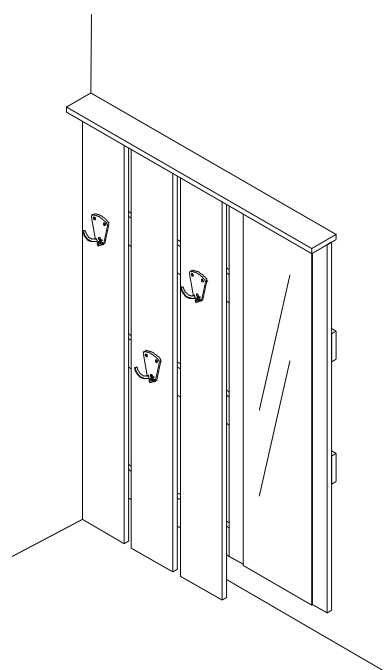
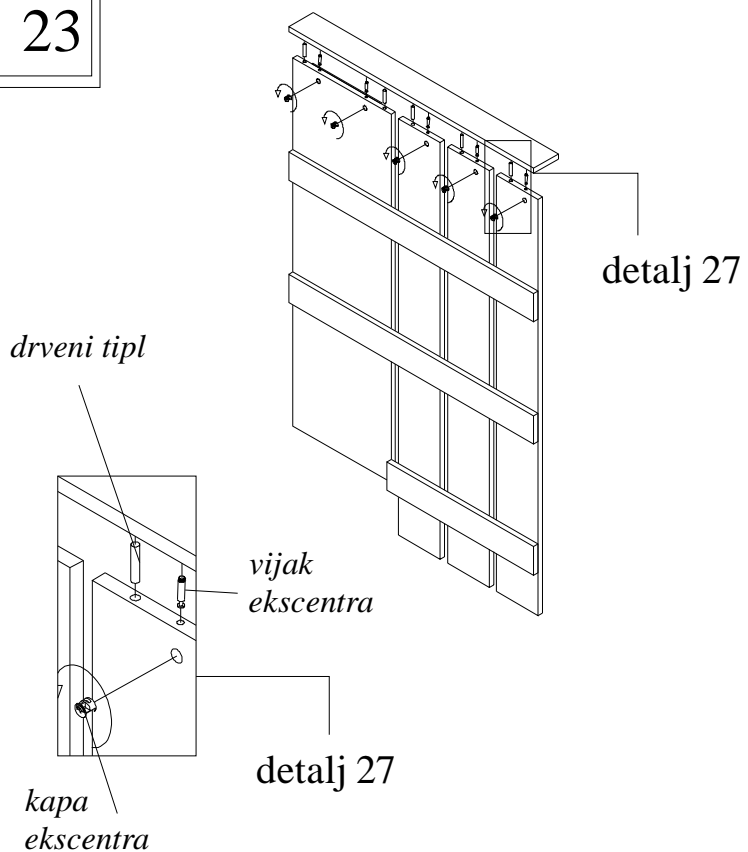

24

25

